

RTD INSERT WITH TRANSITION JOINT

SSKE-31-5

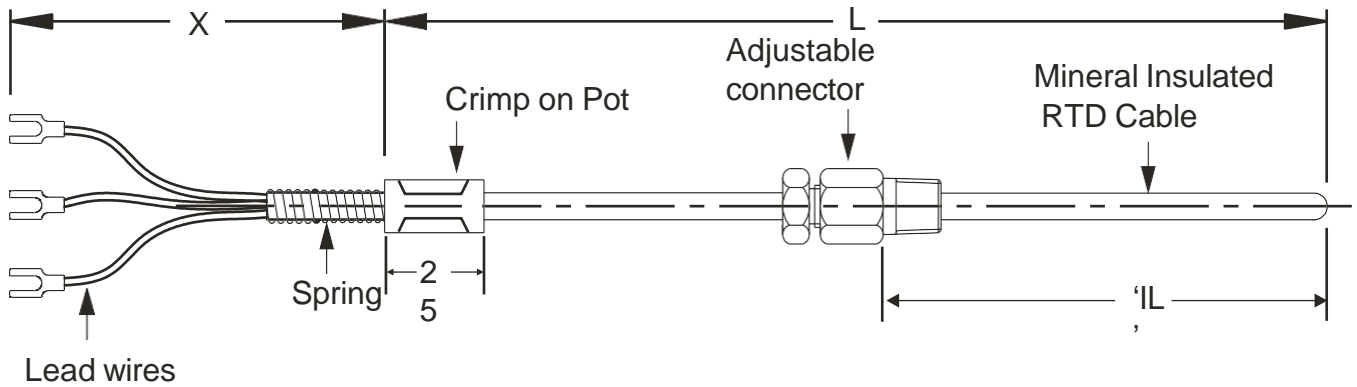

HOW TO ORDER

Code	No of Element
1	Simplex
2	Duplex

Code	Element
Pt -100	Pt-100 RTD
Pt- 500	Pt- 500 RTD
Pt - 1000	Pt - 1000 RTD
Cu - 53	Cu - 53

Code	Range
FLM	-200°C till 449°C
CMC	450°C till 600°C

Code	Accuracy
A	Class 'A' Tolerance as per IEC - 751
B	Class 'B' Tolerance as per IEC - 751

Code	Wire Configuration
2W	2 Wire System
3W	3 Wire System
4W	4 Wire System

Code	Sheath Diameter
3	3.0 mm
3/ 2.8	3.0/ 2.8 mm*
6	6.0 mm
6/ 5	6.0/ 5.0 mm*
8	8.0 mm
8/ 5	8.0/ 5.0 mm*

Consult factory for other diameter.
* RTD Element will be enclosed in Ø3.0 mm SS 316 sheath & Extended by Ø2.8 mm Mineral Insulated lead out cable.

Code	Sheath Material
316	SS 316

Code	Immersion Length 'IL' / Element Length 'L' mm
	Specify in mm.

Code	Lead Wire Length "X" mm
	Specify in mm.

(Ordering Example)

SSKE-31-5	1	Pt-100	FLM	B	3W	6	316	L=300	3000	3	A	SX
	1	2	3	4	5	6	7	8	9	10	11	12

□ Reference standard :- IEC - 751.

SPECIAL

Mineral insulation.
RTD with adjustable process connection for adjustable insertion length.
Mineral insulation enables flexibility and Durability.

APPLICATIONS:

This design is used in General industry for temperature measurement.

STANDARD PRODUCT

No of element	- Simplex
Element type	- Pt-100 RTD
Range	- -200°C till 449°C
Accuracy	- Class 'B' Tolerance as per IEC - 751
Wire Configuration	- 3 Wire System
Sheath Diameter	- 6.0 mm
Sheath Material	- SS 316
Immersion Length 'IL' /	-
Element Length 'L' mm	- L = 300 mm
Lead Wire Length "X" mm	- 3000 mm
Lead Wire Type	- PTFE / PTFE / SS braided lead wire
Process Connection	- 1/2"NPT(M) adj. connector in SS 316
Option Description	- SS Tag Plate

Code	Lead Wire Type
1	PTFE insulated lead wires.
2	PTFE / PTFE insulated lead wires.
3	PTFE / PTFE / SS braided lead wires.

Code	Process Connection
A	1/2"NPT(M) adj. connector in SS 316
B	1/2"NPT(F) adj. connector in SS 316
C	1/2" BSP(M) adj. connector in SS 316
D	1/2" BSP(F) adj. connector in SS 316
	Other, please specify.

Code	Option Description
PW	Five Point Factory Calibration Certificate
SX	SS Tag Plate

Note :

1. When selecting option "PW", please also specify measuring temperature range.

(For e.g. 0/300°C)