

COMMERCIAL PRESSURE GAUGE- STEEL CASE SSKE05-2

APPLICATIONS

- Liquid & gaseous mediums
- Oil & Gas applications
- Food & Beverages

FEATURES

- Follows IS 3624 / EN 837-1 / ASME B40.100
- Accuracy as per $\pm 1.6\%$ / CL 1.6 / Grade A
- Dry / Fillable / Liquid filled



COMMERCIAL PRESSURE GAUGE, SSKE05-2

DESCRIPTION

General

Design : EN 837-1

Accuracy : $\pm 2.5\%$ of full scale

Ambient temperature : $-30...+65^{\circ}\text{C}$

Service temperature : 150°C max.

Pressure limits : Steady pressure up to 75% of FS value

Fluctuating pressure up to 90% of FS value

Short time 130% of FS value for range up to 100 bar

Short time 115% of FS value for range above 100 bar

Joints : Silver alloy brazing / soldering

Material of construction

Sensing element : Bourdon Tube

[<100 bar : C - type , >100 bar : Helical]

Case & Ring material : Mild Steel [MS], powder coated painted [Push fit type]

Bourdon tube & Shank : Copper Alloy

Movement mechanism : Copper Alloy

Dial : Aluminum, black graduation on white background

Pointer : Fixed, aluminum, black powder coated

Window : Sheet glass

Standard version

Dial size : 40 mm / 50 mm / 63 mm / 80 mm / 100 mm
150 mm / 250 mm

Range : $-1...0...700$ bar

Mounting pattern : Direct Bottom

Process connection : $\frac{1}{4}$ " NPT (M) / $\frac{1}{4}$ " BSP (M) / $\frac{1}{2}$ " NPT (M)

Ingress protection : IP 44

Execution : Dry

Temperature effect

When temperature of the measuring system deviates from reference temperature ($+20^{\circ}\text{C}$):

max $\pm 0.4\%$ / 10K of full scale value.

COMMERCIAL PRESSURE GAUGE-STEEL CASE SSKE05-2

DIMENSIONAL DRAWING

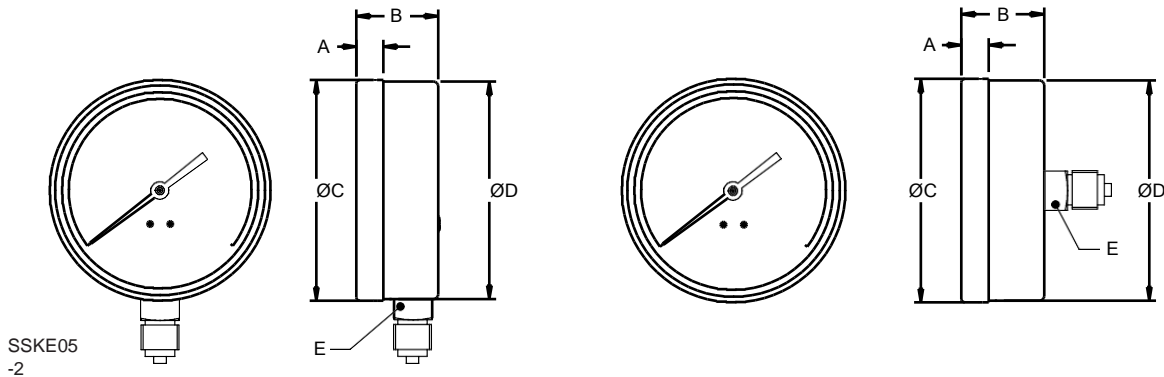

SSKE05
-2

NS	A	B	ØC	ØD	E
50	10	29	53	52	□14
63	12	29	63	62	□14
80	12	35	78	76	□14
100	12	37	98.5	97	□17
150	16	43	155	154	□17
250	37.5	51	252	249	□22

NOTES

- Drawing not to scale. All dimensions are in mm.
- For other mounting details, Panel cut-out dimensions, kindly contact factory.

ORDERING CODES

MODEL	SSKE05-2 Commercial pressure gauge (MS Case)					SSKE05-2
DIAL SIZE						D2
D0	1.5" / 40 mm	D1	2" / 50 mm	D2	2.5" / 63 mm	
D3	3" / 80 mm	D4	4" / 100 mm	D6	6" / 150 mm	
D10	10" / 250 mm					
MOUNTING						M5
M1	Direct bottom	M9	Direct center back with front flange			
M2	Direct bottom with Back flange	M10	Direct center back with panel mounting bracket			
M5	Direct center back					
CONNECTION						P4
P4	¼" NPT (M)	P6	3/8" NPT (M)	P8	½" NPT (M)	
P3	¼" BSP (M)	P5	3/8" BSP (M)	P7	½" BSP (M)	
P1	1/8" BSP (M)	P2	1/8" NPT (M)			
CASE FILLING						F1
F1	Dry					
WETTED PARTS						S12
S12	Copper alloy					
INGRESS PROTECTION						I5
I5	IP 44					
RANGE						0-10 bar
0-10 bar	Please mention range required with the measurement unit [SSKE offer in all types of National & International measurement units, e.g. kg/cm ² , psi, kPa, etc. with single or dual scales]					
OPTIONAL EXTRAS						E23
E23	Cleaned for Oxygen service					

Ordering Example : SSKE05-2.D2.M5.P4.F1.S12.I5/0-10 bar/E23

SHREE SAMARTH KRUPA ENGINEERS

Contact : +91 8155865961, +919586682557

prakash@shree-samarthkrupa.com, www.shree-samarthkrupa.com

